

# TYRE CHANGER

---

# USER MANUAL

---

Pls read this manual before operation

---

Dear customers,

Very pleased that you will purchase and use the tire changer produced by our company

We are the company with reputation of quality. We sincerely wish to produce quality goods under the ISO9001 Quality system and get the EU CE certificate to help you promote your business.

Carefully read this operational manual before installation and use this operation manual. And also keep it with care for future reference.



**WARNING**

This instruction manual is the important part of the product. Please read it carefully and keep it properly.

This machine is only applied to mount, demount and inflate the tire in the specified scope and not for any other purpose.

The manufacturer will not be responsible for the damage or injury caused for the operation not properly and out of the range.

---

## NOTE

This machine should be operated by the special trained qualified personnel. When operating, the unauthorized personnel will be kept far away from the machine.

Please note the safety label stuck on the machine.

Operators should wear safety protective facilities such as working suit, protective glasses, and eye plug and safety shoes. Keep your hands and body from the movable parts as possible as you can. Necklace, bracelet and loosen clothing may cause dangerous to the operators.

Tire changer should be installed and fixed on the flat and solid floor. The more than 0.5m of distance from the rear and lateral side of the machine to the wall can guarantee the perfect air flow and enough operation space.

Do not place the machine in the site of high temperature, high humidity, and dust with flammable and corrosion gas.

Without the permission from the manufacturer, any change on the machine parts will cause injury/damage to the machine/operator.

Pay attention that the tire changer should be operated under the specified voltage and air pressure.

If you want to move the tire changer, you should under the guidance of the professional service personnel.

## SAFTTY LABEL INSTRUCTION

 <b>CAUTION</b>	 <b>WARNING</b>	 <b>WARNING</b>
		
<p>KEEP HANDS CLEAR OF BEAD AREA WHEN INFLATING.</p>	<p>BE SURE TO READ ALL WARNING LABELS AND INSTRUCTION MANUAL PRIOR TO OPERATION OF THIS MACHINE</p>	<p>ALWAYS WEAR SAFETY GLASSES WHEN OPERATING THIS MACHINE</p>



electrical shock !



Do not reach any part of your body under the demount tool.



When breaking bead, the bead breaking blade will quickly move leftwards.



When clamping the rim, do not reach your hand or other parts of the body in between the clamp & the rim.



Note: when press the tire, the opened clamp cylinder may injury the hand of the operator. Remember, do not touch the side wear the goggle wall of the tire.

 **DANGER**



STAND CLEAR WHILE INFLATING TIRE. TIRE OR WHEEL FAILURE UNDER PRESSURE MAY CAUSE SERIOUS INJURY OR DEATH.

 **WARNING**



DO NOT WEAR LOOSE CLOTHING, LONG HAIR OR JEWELRY. MOVING PARTS CAN SNAG AND PULL

 **WARNING**



KEEP HANDS CLEAR OF ALL PINCH POINTS

LA009

LA008

## SAFETY LABEL POSITION DIAGRAM

Pay attention to keep the safety labels complete. When it is not clear or missing, you should change the new label.

You should let the operators see the safety labels clearly and understand the meaning of the label.

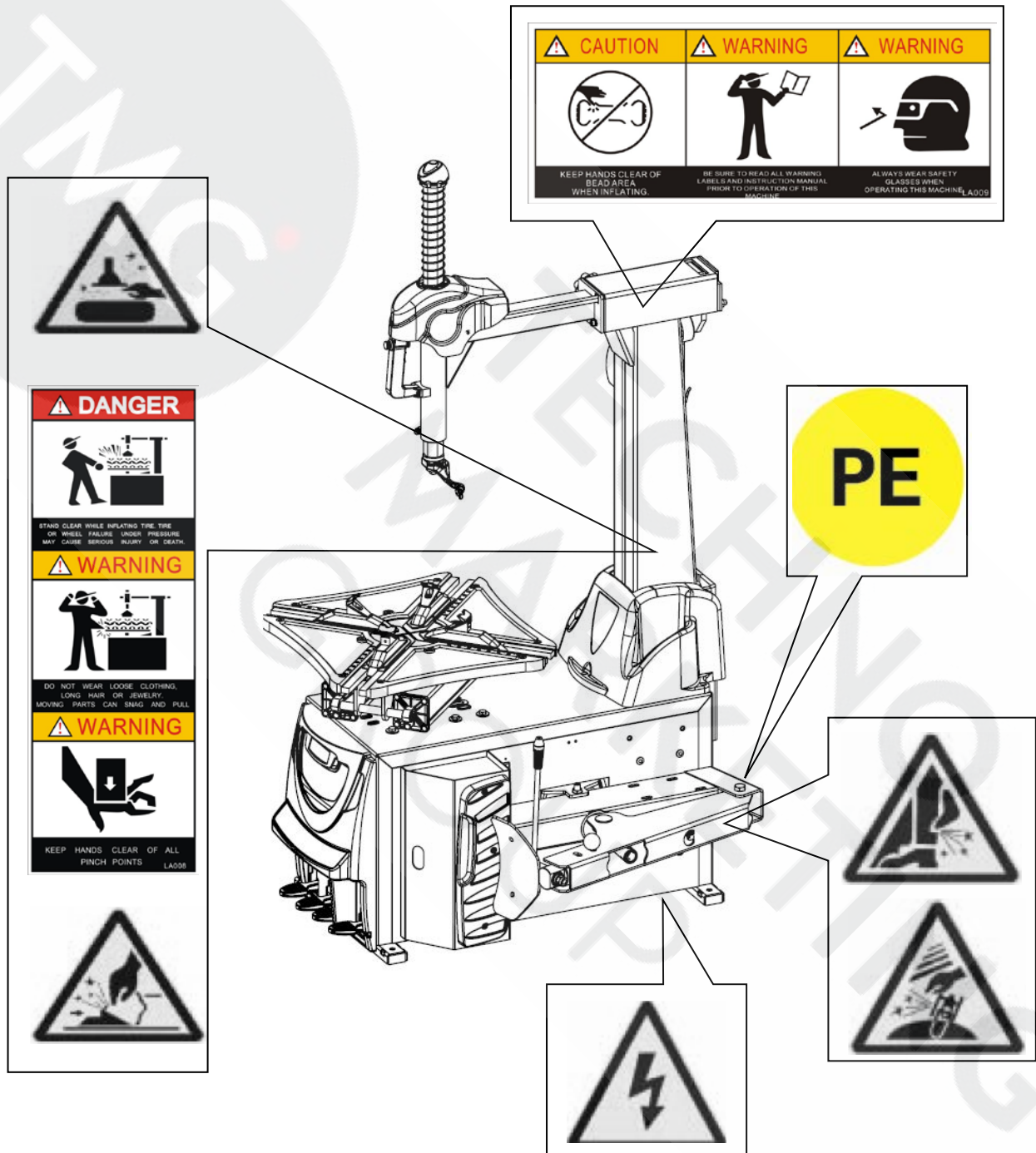



# CONTENTS

CHAPTER 1	<b>BRIEF INTRODUCTION</b>	1
●	1.1 BRIEF INTRODUCTION	1
●	1.2 EQUIPMENT OVERALL DIMENSION	1
●	1.3 TECHNICAL PARAMETER	1
●	1.4 WORK ENVIRONMENT	2
CHAPTER 2	<b>BASIC CONSTRUCTION AND OPERATIONAL PARTS</b>	4
CHAPTER 3	<b>INSTALLATION AND CALIBRATION</b>	5
●	3.1 UNPACKING	5
●	3.2 INSTALLATION OF THE PARTS DETACHED	5
●	3.3 AIR TEST	9
CHAPTER 4	<b>DEMOUNT/MOUNT</b>	10
●	4.1 BASIC PRINCIPLE	10
●	4.2 DEMOUNT TIRE	10
●	4.3 MOUNT TIRE	11
●	4.4 INFLATION	12
CHAPTER 5	<b>REPAIR AND MAINTENANCE</b>	13
CHAPTER 6	<b>TRANSPORTATION</b>	14
CHAPTER 7	<b>ELECTRICAL AND PNEUMATIC PRINCIPLE DIAGRAM</b>	15
CHAPTER 8	<b>COMMON TROUBLESHOOTING</b>	19

## Chapter 1 Brief Introduction

### 1.1 brief introduction

889N tire changer is the tire changer featured with tilt and horizontal arm, suitable to mount, demount and inflate all types of car tire with tube and tubeless. The operation is easy, convenient and safety. It is the necessary equipment for the auto service shop and tire shop.

### 1.2 overall dimension

Model	H(mm)	L(mm)	B(mm)	NT(kg)
LC889N(regular):	1900	1400	2050	285
GT889N(with quick inflation-install the air tank)	1900	1400	2050	295

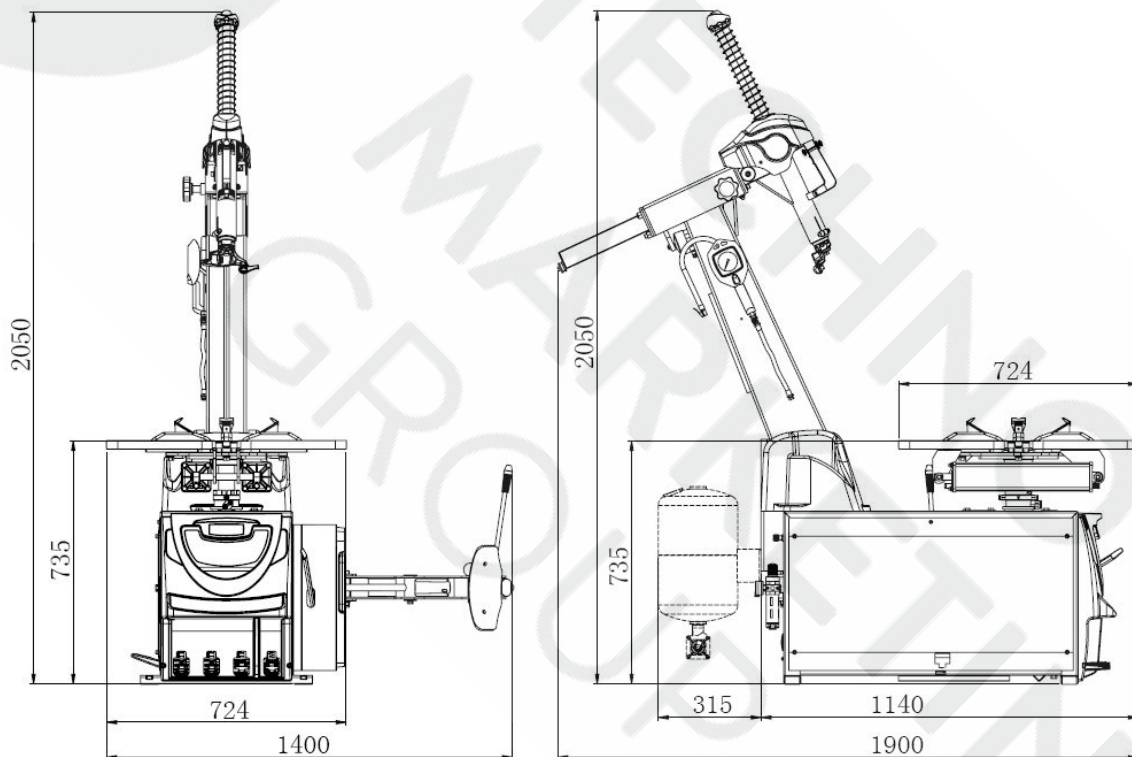

### 1.3 technical parameter

Work pressure: 8-10bar

Turntable speed: 6.5rpm

Working Noise: <70dB

Motor parameter:

Voltage(V)	110	220	380
Frequency(Hz)	50, 60, 50/60	50, 60, 50/60	50, 60
Power (Kw)	0.75-1.1	0.75-1.1	0.75-1.1

Application range:

Model	Max. wheel diameter	Max. wheel width	Rim diameter (outward clamp)	Rim diameter (inward clamp)
LC889N GT889N	1100mm(43")	381mm(15")	1 <sup>st</sup> gear 11"~22" 2 <sup>nd</sup> gear 12"~23" 3 <sup>rd</sup> gear 13"~24"	1 <sup>st</sup> gear 13"~24" 2 <sup>nd</sup> gear 14"~25" 3 <sup>rd</sup> gear 15"~26"

Like showing in FIG1, the model 887N/GT887N machine equips the adjustable turntable. The default setting is at the second gear (12"~23" & 14"~25") when leaves factory. The operator can adjust the different gear according to the FIG1 showing in order to mount and demount kinds of rims. (Note: the FIG1 shows the outward clamp range and must change the four clamp at the same time when change the gear).

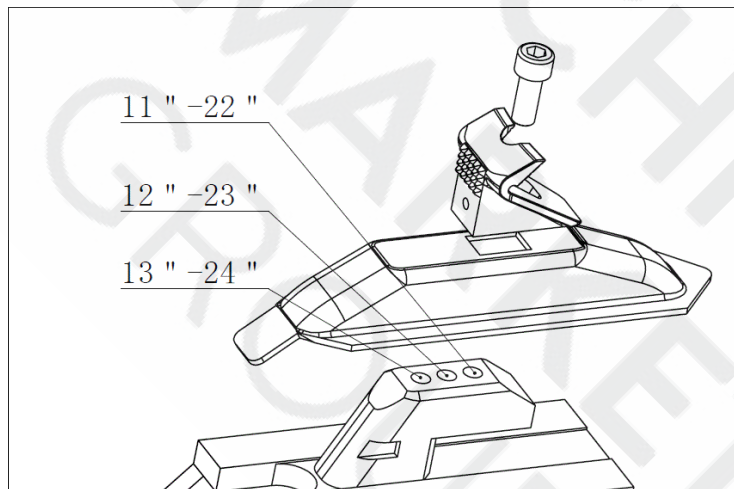

FIG1

#### 1.4 work environment

- Environment temperature: 0°C~45°C
- Relative humidity: 30~95%
- Max. Altitude: 1000M
- Without dust and without gas easy to explosive and rusty.
- The space around machine is not less than indicated in Fig2.
- Forbidden to be used in the place containing the gas flammable!



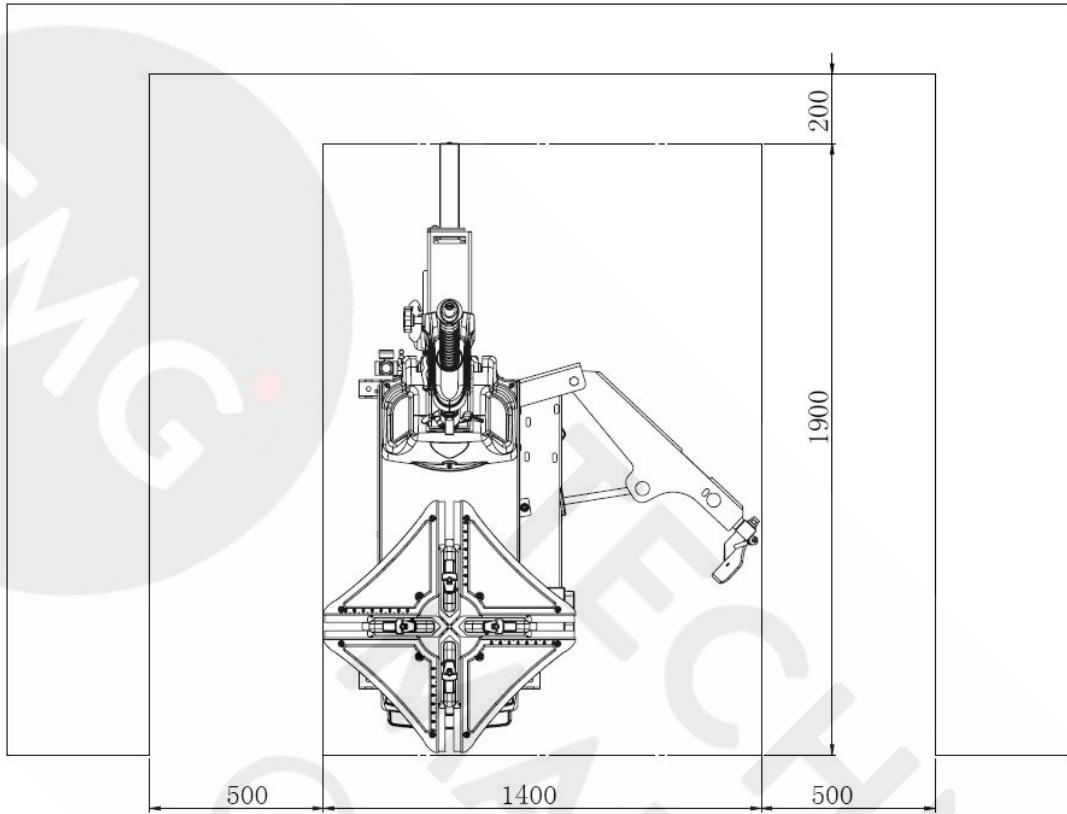

FIG2

## Chapter 2 Basic Construction and Operational parts

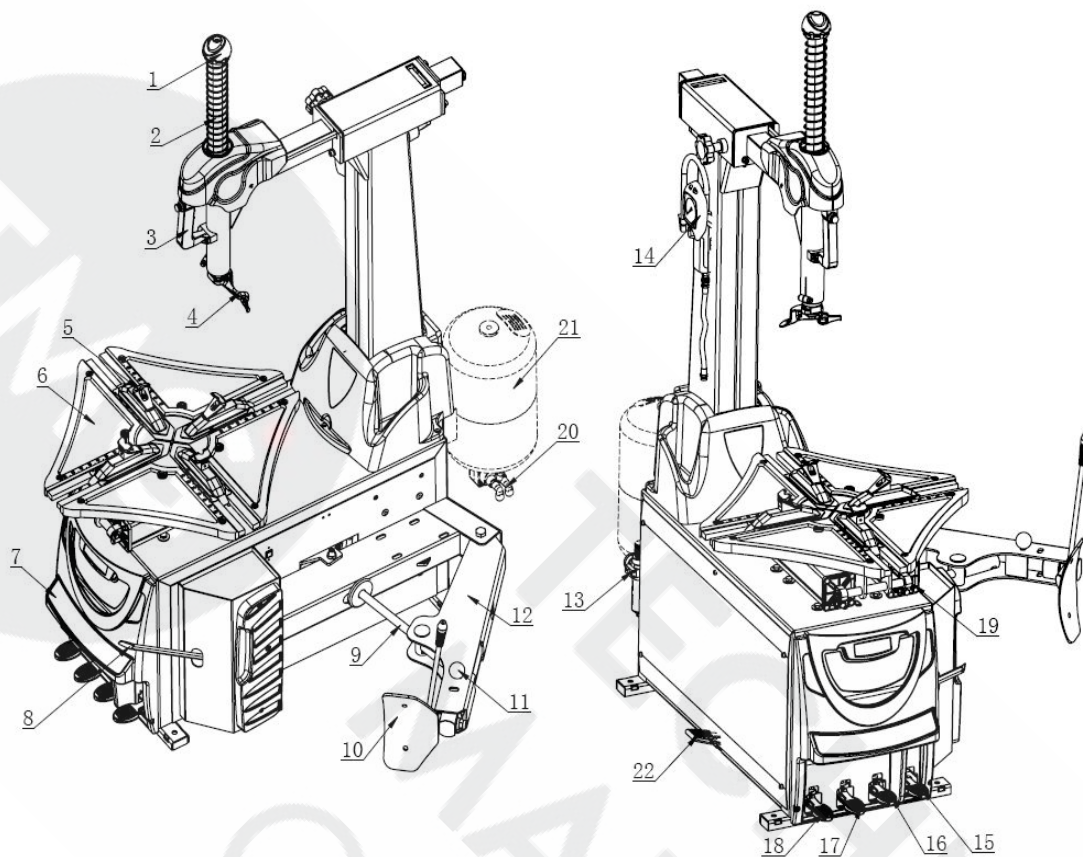

FIG3

- |                          |                            |
|--------------------------|----------------------------|
| 1 —knob                  | 14—inflation gun           |
| 2 —hexangular shaft      | 15—turntable turning pedal |
| 3 —handle valve          | 16—bead breaker pedal      |
| 4 —demounting head       | 17—clamp pedal             |
| 5 —clamping jaw          | 18—column tilt pedal       |
| 6 —turntable             | 19—clamping cylinder       |
| 7 —front panel           | 20—exhaust valve           |
| 8 —crowbar               | 21—air tank                |
| 9 —bead breaker cylinder | 22—quick inflation pedal   |
| 10—breaker blade         |                            |
| 11—shift pin             |                            |
| 12—bead breaker arm      |                            |
| 13—air regulator         |                            |

Note: 20, 21, 22 only for GT889N model

## Chapter 3 Installation and Commission



Carefully read the manual before installation and the change on the parts of the machine without the permission of the manufacturer can cause the damage to the machine;

- Installation and commission person must have some knowledge relating to electrical;
- Operator must under the special training and pass the examination;
- You must carefully check the equipment list and contact the dealers or our company if you are in doubt;
- To ensure the installation and commission complete successfully, please prepare the following common tools: 2pcs open spanners (10"), 1 pc socket key, 1pc hexangular spanner, 1pc pliers, 1pc screw, 1pc hammer and 1pc universal electric meter.

### 3.1 Open the box

3.1.1 In accordance with the instruction on the package box, open the package box and remove the package material and check if the machine is sounded and the accessories if completed.

3.1.2 Keep the package material far away from the working site and treat it well.

### 3.2 installation of the parts detached

#### 3.2.1 Installation of the air tank

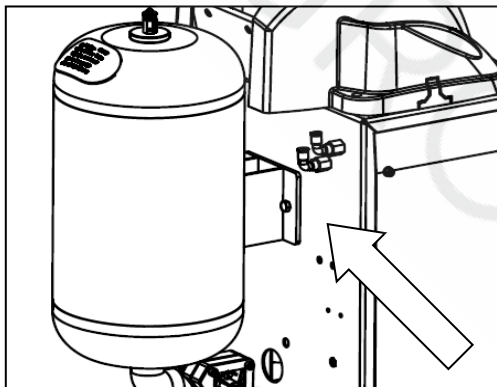

FIG 4

- Remove the side panel and use 2 pcs M8x25 bolts to connect the air tank at the rear of the body.
- Use the flat washer (GB95-87) and elastic washer (GB93-87) and nut (GB6170-85) to fix the air tank in main body of machine.
- The condition of the machine after installation is as indicated in Fig4.

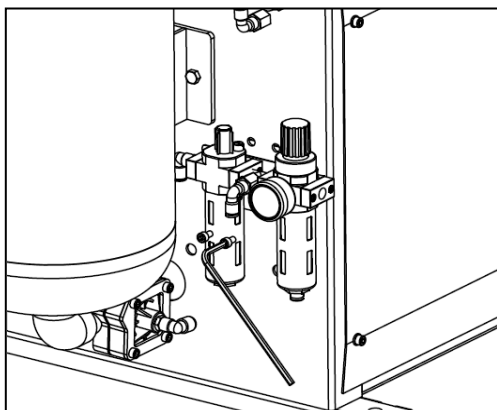

FIG 5

#### 3.2.2 Install the air regulator

Install the air regulator to the right side of the air tank using 2 pieces of M6x10 screw by 5# Allen key like FIG5.

- After installation air regulator, remove the straight connector which connect the two pcs of  $\phi 8$  PU hose like FIG6-1 & FIG6-2. (This connector

can avoid the PU hose to back into the main body.

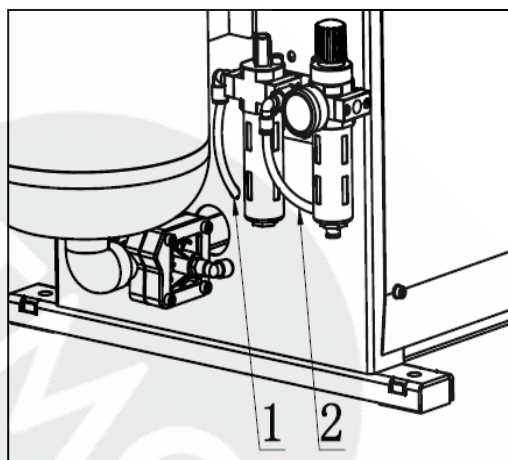

FIG 6

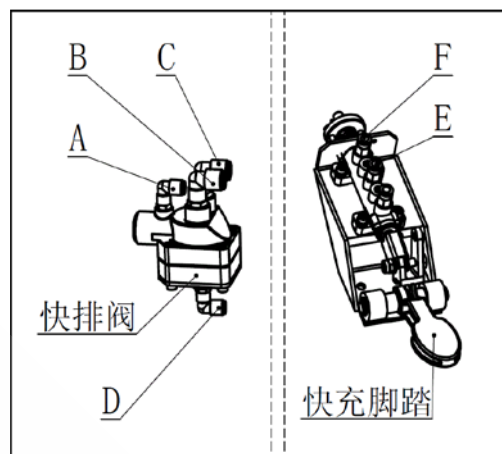

FIG 7

- b) Connect the PU hose into the connectors of air regulator like FIG6. (if the machine is without the GT function, just need to connect the hose like FIG6-1).
- c) If the machine has the air tank (FIG2-20), connect the holes FIG7-A to FIG6-2.
- d) Connect FIG7-D to FIG7-F.
- e) Connect FIG7-E to FIG6-2. (The "hole" FIG6-2 is the TEE)

### 3.2.3 Install the bead breaking arm

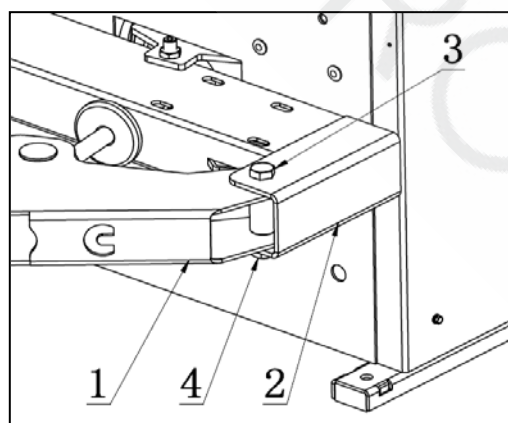

FIG 8

- a) As shown in FIG8, align the installation hole of bead breaking arm (FIG8-1) to the installation hole of bead breaking arm bracket (FIG8-2). Plug in the pin shaft screw (FIG8-3) and then tighten the lock nut (FIG8-4).
- b) As shown in Fig9, plug cylinder rod (FIG9-1) into the hole of bead breaking arm slide bush (FIG9-2). Twist the adjusting device (FIG9-3) onto the end of cylinder rod.

- c) Hang the spring (FIG9-4) like the FIG9.

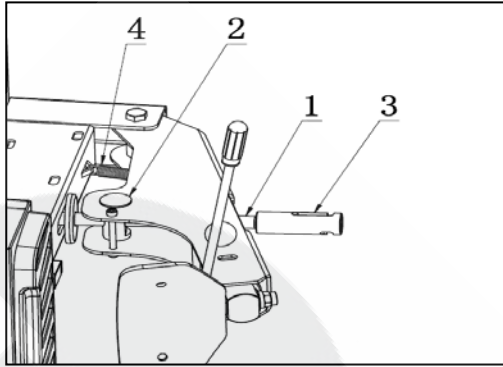

FIG 9

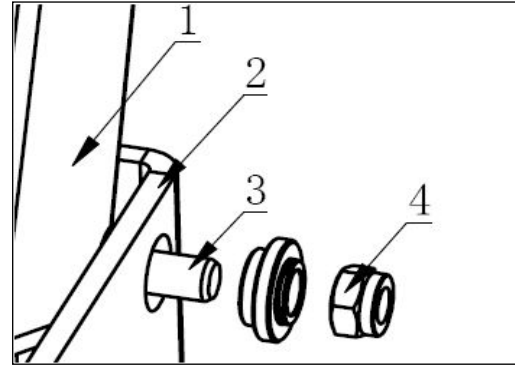

FIG 10

### 3.2.4 Installation of the column assembly



FIG 11

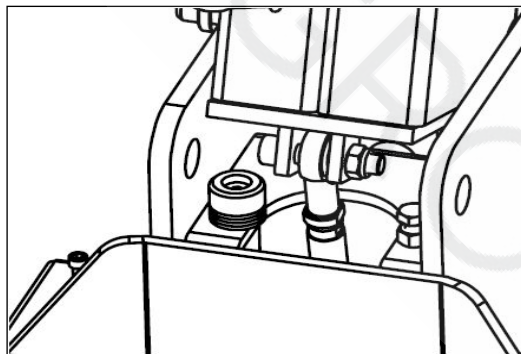

FIG 12

- a) Position the column (FIG10-1) at the upper block of the body (FIG10-2). The surface of the column that label is stuck on should be forward.
- b) Align the installation hole and plug in the column rotation shaft (FIG10-3), and use the bolt (FIG10-4) to lock two sides.
- c) Connect of column with the tilt back cylinder: Align the hole (FIG11-2) at the end of the cylinder rod and the installation hole at the bottom of the column.
- d) Use the 10# Allen key to insert the bolt M12X50 (FIG11-1) to the body upper base like FIG11. Connect the column and the tilt cylinder then fix them using nuts (FIG11-3).
- e) The condition after installation is like FIG12.
- f) Connect the column air hose: insert the  $\phi 6$  (FIG13-1) into the connector (FIG13-A) behind the body like FIG13.
- g) Installation of the column protective cover: Position the protective cover (FIG14-1) at the upper block of column. Align the hole and install it using 4 pcs M6 screws as shown in FIG14.



### 3.2.5 Connect the inflation gun or inflation gauge.

Take out the inflation gun then connect it the open nut and tighten it. Hang the gun to the hook after installation.



图 13



图 14

Install the inflation gauge (FIG15-3): fix it to the installation hole at the side of column using two pcs M6 screws (GB70-85). Then connect the  $\phi 8$  hose (FIG15-1) on inflation gauge to the elbow (FIG15-2) on the machine body back (FIG15).

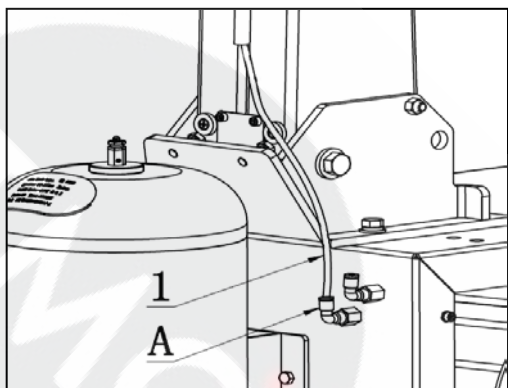
### 3.2.6 Installation of the vertical shaft spring and horizontal arm cover.

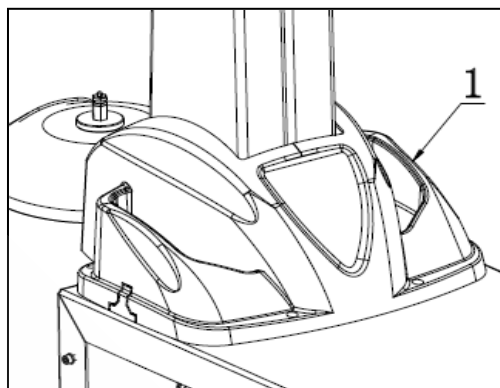
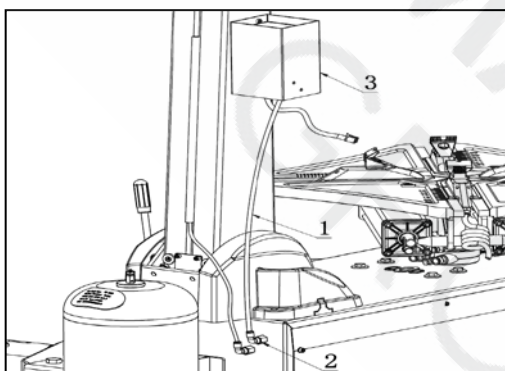

FIG 15

When you detach the vertical shaft cap, you should support the hexangular shaft properly to avoid the fall of the hexangular shaft causing the damage to the machine or the human body.

- a) Detach the vertical shaft cap (FIG16-2) and the fix screw (FIG16-1) and mount the vertical shaft spring (FIG17-1) and then fix the vertical shaft protection cover (FIG17-2), then fix the shaft cap.

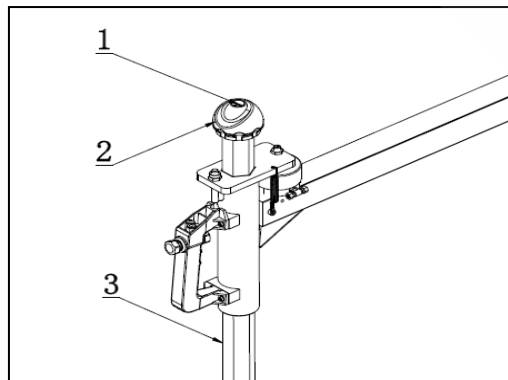

FIG 16

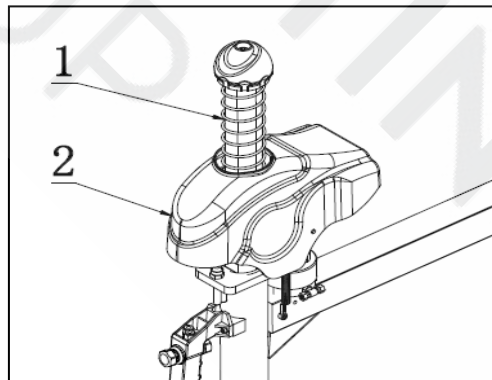

FIG17

- b) Install the horizontal arm cover (FIG17-2) from the top of the hexangular shaft. Use the

screws M6x10 to fix it from the side. When installation, add the spacer inside of the cover to avoid damage the cover.

### 3.3 Air test:

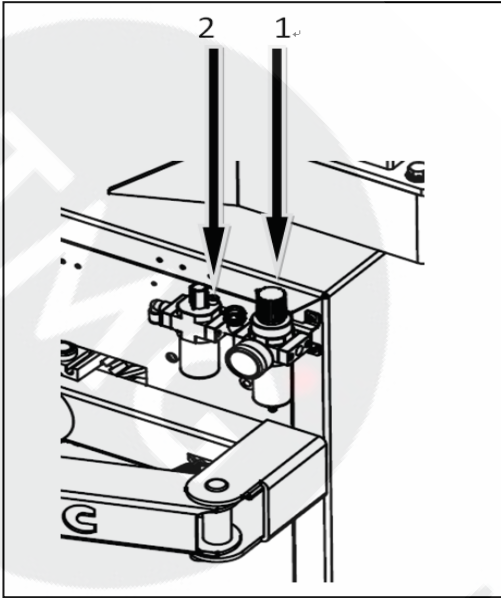

FIG 18

- a) Column tilt back: Connect the air and press down the lock valve button (FIG3-3) to lock the horizontal arm. Step down column tilt pedal (FIG3-10) and the column tilt back by 25°.
- b) The tilt speed has been setup before ex-work at about 2 seconds.
- c) After longtime of use, the speed will be fast or slow and on this condition, you can use the speed valve at the heads of the push-out cylinder to adjust. Loose the nut and turn adjust screw clockwise, the speed will be slow and it will be slow if counterclockwise, tight the nut after adjust. When the machine out of the factory, the air source fitting has been adjusted well and if you need to change, you can readjust.
- d) Before the machine out of the factory, the air regulator has been adjusted well and can be re-adjust if need. Adjust the pressure: lift-up the adjusting knob (FIG18-1) and rotate it clockwise, the pressure will raise. Otherwise, decline. Press down the adjusting knob after adjusting.
- e) Adjust the oil feed: twist the adjusting screw (FIG18-2) clockwise using the screw driver to slow the dripping speed and otherwise, quicken it.

## Chapter 4 Demount/Mount

Note: the operator must be trained and qualified then allow to operate the tire changer. Need to use the proper device and tools, wear the protective clothes, and use the proper safety precautions, like goggle, earplug, and safety shoe and so on.

### 4.1 BASIC PRINCIPLE

- In order to avoid damage the rim, especially the alloy rim, when mount and demount the tire, must use the specified crowbar.
- In order to facilitate the removal and protection the tire and rim, between the tire and rim, at the position which the bead break blade insert to, need to lubricate using industrial lubricants or soap water.
- For certain types of tires, pay attention to the tire wall and the rotation direction marked on the tire.
- The tire size must be suitable for the rim to mount.
- Before mount and demount the tire, need to check whether the rim had damage (deformation or surface of the outside of the rim, rim axial for radial beat is too big, corrosion or overall wear).
- In any case, pay attention to the mounting and demounting request of the special tire from the tire manufacturers.
- When inflate the tire, to increase the pressure uniformly and pay attention to the tire edge situation.

### 4.2 DEMOUNT TIRE

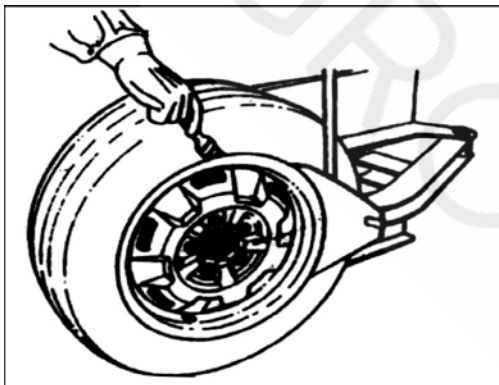

FIG 19

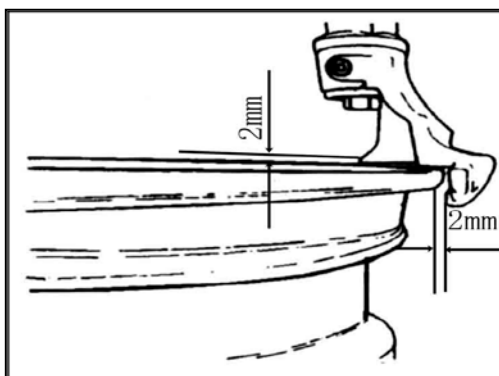

FIG 20

a) Deflate the air in the tire completely and pull out the core. Use the special tool to detach the weight on the rim.

b) Place the tire between then bead breaking blade and tire pressing runner clog (FIG19).

c) Then step down the tire press pedal (FIG3-16) to detach the rim from the tire. Repeat

the same operation on the other parts of the tire to make the tire completely detached from the rim. Can use the adjusting device (FIG3-11) to shift the gear to suitable for the different thickness tire.

d) Place the wheel with the tire detached from the rim on the turntable and step the clamp pedal (FIG3-17) to clamp the rim.

e) Move the hexangular shaft to the working position to make the demount tool close to the rim of the wheel. The cylindrical roller in the demount tool will contact with the external rim of the rim and the bottom of the demount tool will contact with the surface of the rim.

f) Press the lock handle press button (FIG3-3) to lock horizontal arm and hexangular shaft and the hexangular shaft will automatically move upwards. The quadric shaft will automatically backward a little to make the demount tool detached from the rim of the rim to avoid the damage on the rim (FIG20).

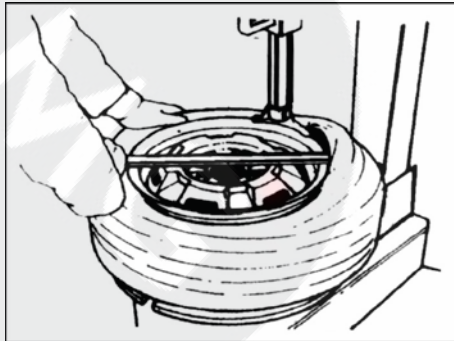

FIG 21

NOTE: The angle of the demount tool has been calibrated according to the standard rim (14"). If handling the extra-big or extra-small rim, you can reposition.

g) Use the crowbar to detach until the lip to the hump of the demount tool (FIG20). Step the turntable rotation pedal (FIG3-15) to rotate the turntable clockwise until the rim of the wheel fall off.

If handling the tube tire, to avoid the damage on the tube, you should keep the nozzle of the tire 10cm from the right side of the demount tool.

NOTE: If the demount of the tire is jammed, please stop the machine immediately and then lift up the pedal to let the turntable rotate counterclockwise to remove the resistance!

h) Take out the tube and then move up the lower lip to contact with the upper edge of the rim and detach another lip (FIG23). Step the column tilt pedal (FIG3-10) and the column tilt backwards and at this moment, you can take off the tire.

#### 4.3 Mount tire

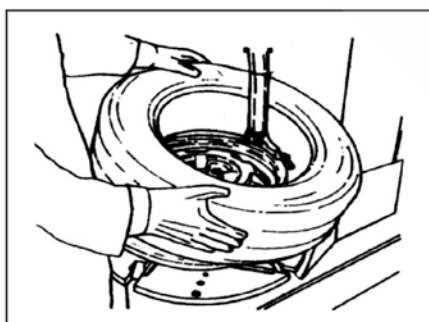

FIG 22

a) Clean up the oil and rust on the rim and lock the rim on the turntable.

b) Spread the lubrication liquid or soap liquid around the lip. Tilt the tire against the rim and keep the front end upwards. Press down the column tilt pedal (FIG3-18) to make the column return to the original position. Move the demount head to firmly

contacted rim (FIG20). Position the left of the lip above the tail of the demount tool and the right under the hump of the demount tool (FIG22).

c) Press down the right side of the tire as hard as you can and step turntable pedal (FIG3-15)

---

to rotate the turntable clockwise to guide the lip into the tire detach slot completely.

- d) If there is tube, raise up the demount tool and put in the tube and position the core.
- e) Mount the demount tool again. Adjust the position of the upper lip. Use the assistant press roller and press to press the side of the tire to make partial of the lip into the tire detaching slot (FIG24). Step the turntable rotation pedal to rotate the tire. At this moment, continue pressing the lip just mounted on the rim.

NOTE: When 10~15cm of the tire not into the rim, change to the step mode. And observe the condition of the tire to avoid the tear of the tire. Once you feel there is any tear on the tire, release the pedal at once. Then lift up the pedal by instep to make the motor rotate reverse. Make the tire restore to the original condition to mount again.

#### **4.4 Inflation**

NOTE: When inflating the tire, please be carefully and series obey the operation process. Check the air route to see if the air connection is OK. This machine is equipped with an inflation device (inflation gun or inflation gauge) for monitoring the inflation of the tire and the inflation pressure.

##### 4.4.1 Regular inflation

- a) Loose the tire from the turntable.
- b) Connect the inflation hose with the tire air core.
- c) In the process of inflation, you should repeat stepping the inflation pedal. Confirm the pressure indicated on the pressure gauge not exceed the scope specified by the manufacturer. In this machine, there is a pressure decrease valve to keep the inflation pressure not exceed 3.5bar. Customers can get different inflation pressure by adjusting the pressure decrease valve according to their own requirement.
- d) If the inflation pressure too high, you can press down the deflation press button on the inflation device to reach the required air pressure.

##### 4.4.2 Rapid Inflation (only for the machines with IT)

NOTE: Must make sure the wheel was clamped firmly to avoid the risk.

- a) Clamp the wheel and connect the inflation hose.
- b) Step down the inflation pedal (FIG3-23) to the bottom position (second gear) and quickly release the pedal when the tire is full to the position of the first gear.



c) Repeat stepping the pedal for many times to confirm the pressure indicated on the pressure gauge not exceeds the pressure specified by the manufacturer.

### **Warning! Explosive!**

When inflation, you must follow the above safety operation and abide by the following instruction:

- Carefully check is the size of the rim same to the size of the tire and also check the wear condition of the tire to secure there is no damage before inflation.
- When the inflation pressure is relatively high, you should remove the tire from the machine and inflate in the protective cover.
- When inflate the tire, be carefully, keep your hands and body far away from the tire.

## **Chapter 5 Repair and Maintenance**

Note: Only the professional personnel can repair. Before any operations of repair and maintenance, you should power off and the power plug should be monitored by the repair personnel, meanwhile switch the pneumatic source and deflate the residual gas.

### **5.1 The following parts will be maintained monthly:**

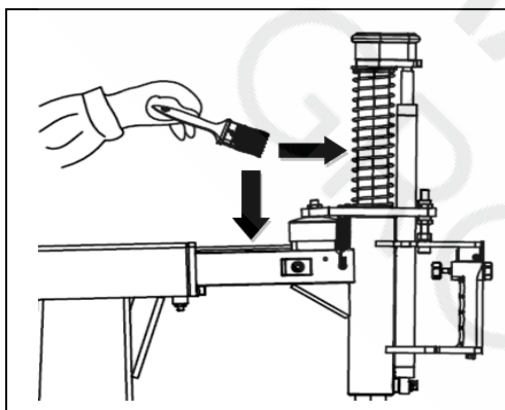

**FIG 23**

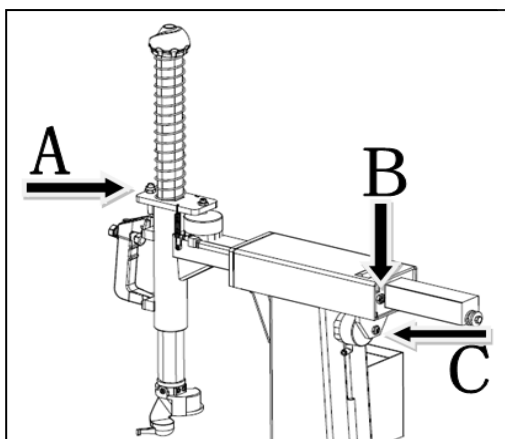

**FIG24**

- Keep the clean of machine and working site.
- Use the diesel oil to wash the hexangular shaft and quadric horizontal arm (Fig23).
- Use the diesel oil to clean the turntable jaw and guide rail and use the Lithium grease to lubricate.
- Periodically check the height of the in the oil fogger. If it is lower than the oil scale, please fill in the SAE30 grease. Periodically drill out the water and impurity in the oil-water separator.
- Periodically check and adjust the tension force of the transmission belt and properly adjust the adjustable nuts at the A and B position to adjust the tension of the belt.
- Check all the connecting part and tight the

---

loose bolts.

## 5.2 The adjustment on the clearance between the tool head and rim.

- Switch off the pneumatic source and detach the protective cover on the hexangular shaft. If the clearance is too much, we can adjust the nuts (Fig24-A) on the vertical hexangular shaft downward by 16# spanner; if the clearance is too small we can adjust the nuts on the vertical hexangular shaft upward.
- Switch off the air source and detach the protective cover at the upper end of the horizontal arm. Use 5# spanner to loosen the lock nut (Fig24-C) on the M6 screw at the two ends. Adjust the M6 screw, meanwhile use your hand to push the quadric shaft until it runs smooth and then lock the nut. Use the spanner to adjust the screw in the middle and meanwhile lock the horizontal arm and observe the displacement. When the displacement is 2mm, lock the nut.
- If the square locking plate cannot lock firmly, adjust the taper locking pole.(FIG24-D)

## Chapter 6 Transportation

When transporting the machine, you must use the original packaging and place it according to the mark on the package. The machine must be transported by a forklift with the corresponding tonnage (Fig25) and the stacked layer will not exceed 3 layers.

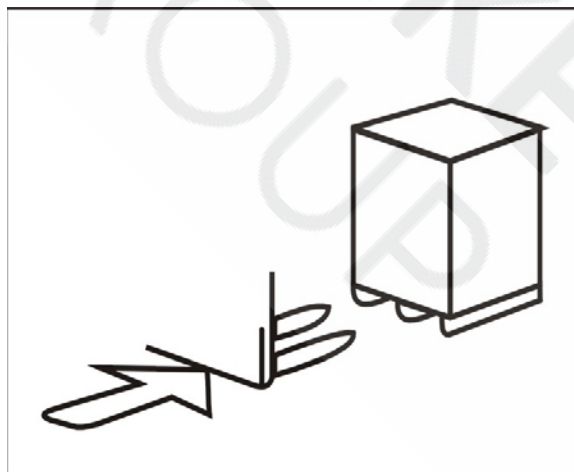
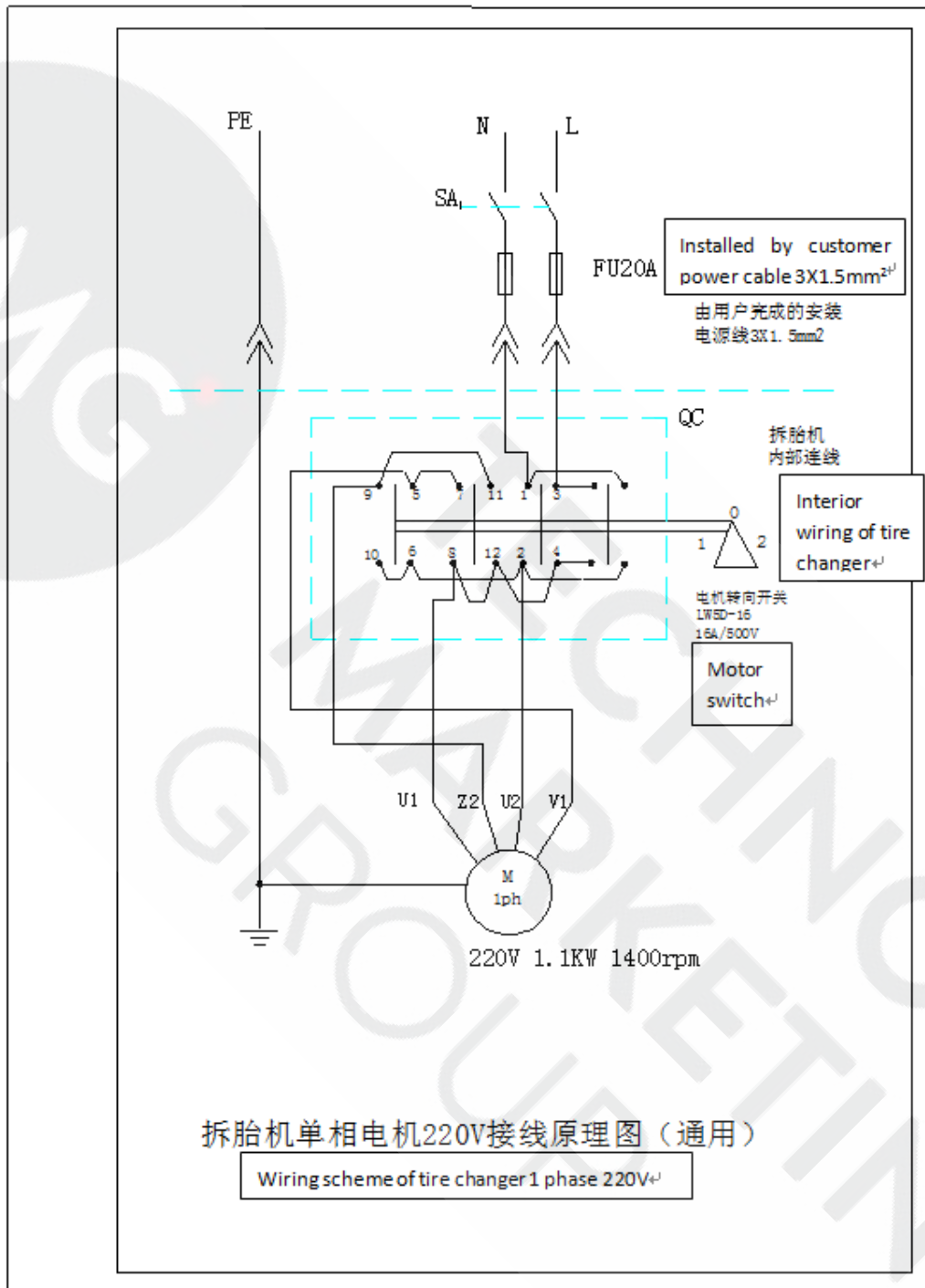

FIG 25

## Chapter 7 Electrical and pneumatic principle diagram

### 7.1 220V ELECTRICAL PRINCIPLE DRAWING



7.2 380V ELECTRICAL PRINCIPLE DRAWING

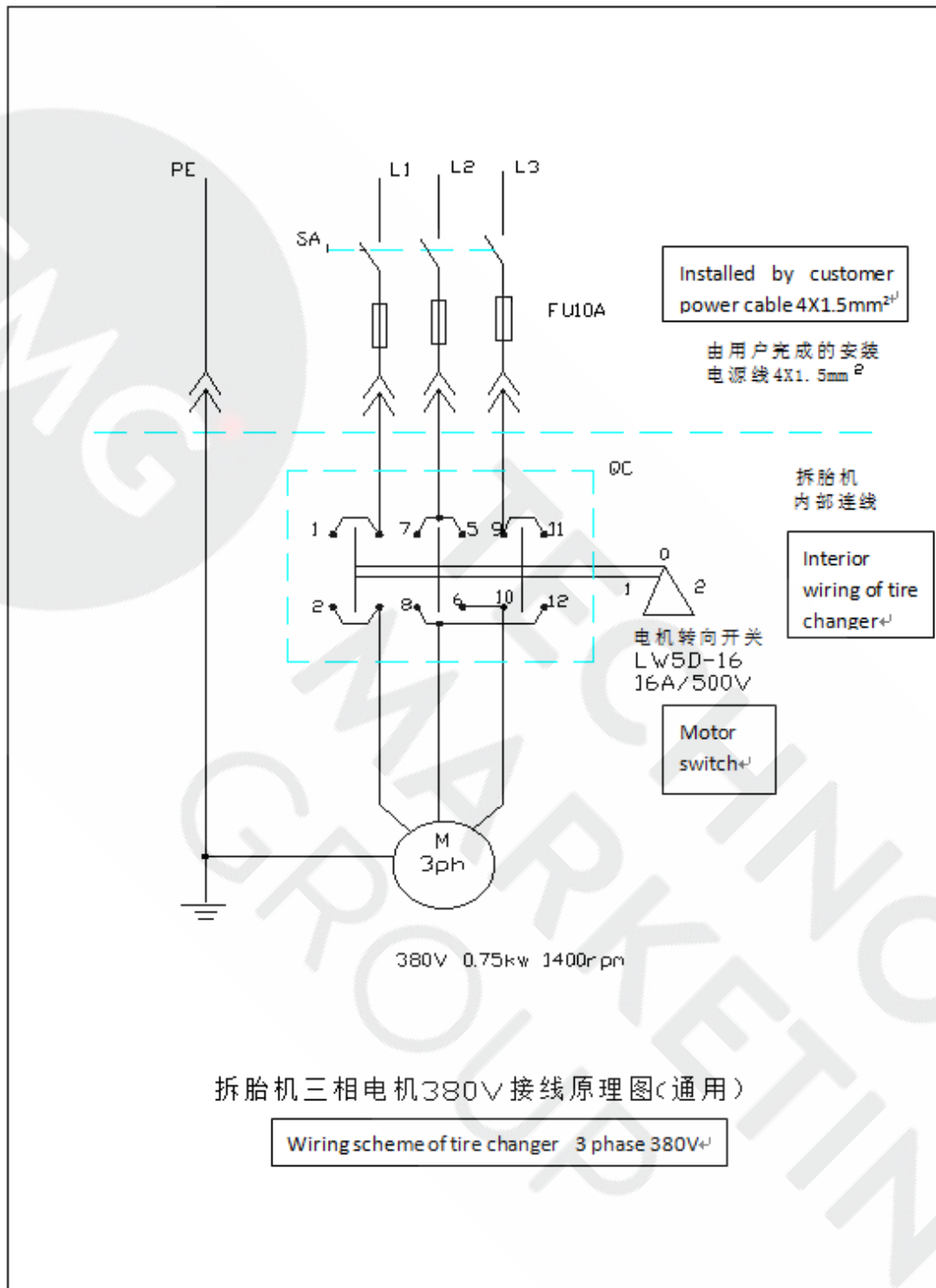

7.3 110V/220V ELECTRICAL PRINCIPLE DRAWING

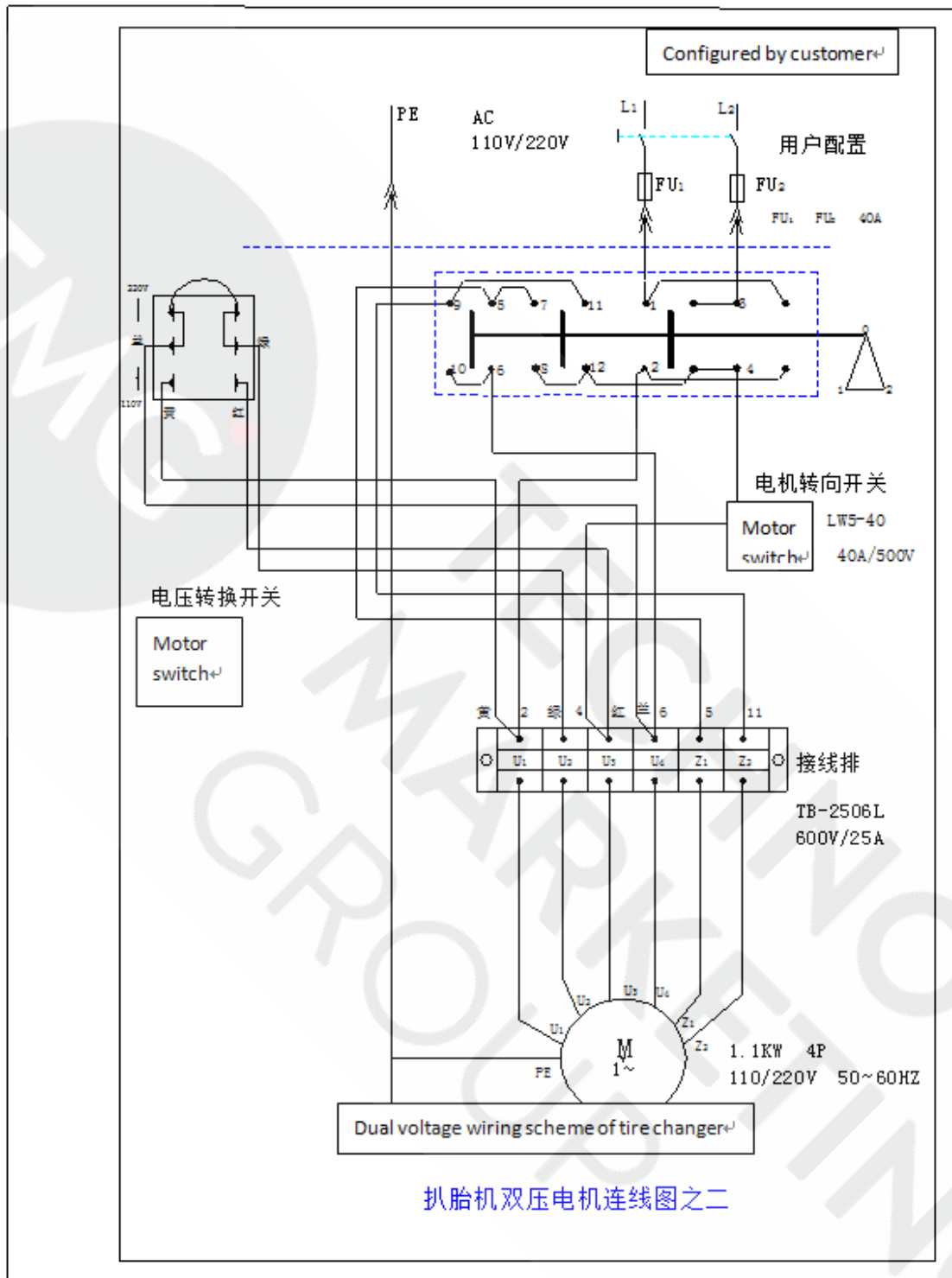



### 7.4 PNEUMATIC PRINCIPLE DRAWING

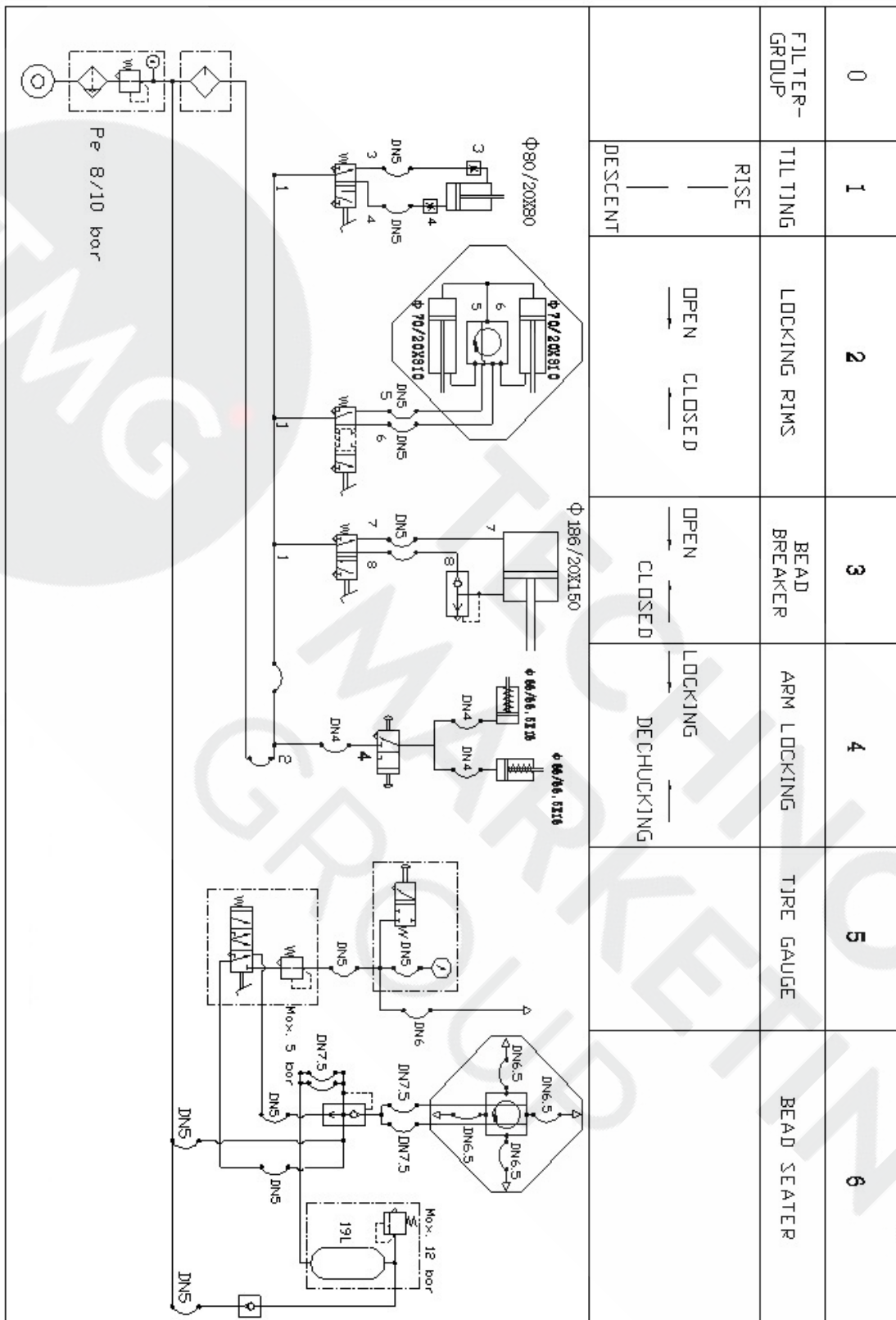

## Chapter 8 common troubleshooting

TROUBLE	REASON	TROUBLESHOOTING
Turntable rotates in one direction.	Universal switch contact burned	Change Universal switch
Turntable does not rotate.	Belt damage Belt too loose Motor or power source have problems  Universal switch contact damage	Change belt Adjust the tension of the belt Check motor, power source and power source cable Change motor if motor burned Change Universal switch
Turntable cannot clamp the rim as normal	Claw worn Clamp cylinder air leakage	Change claws Change the air leakage sealing parts
Quadric and hexangular shaft cannot lock	Lock plate not in position	Refer to the chapter V
Horizontal arm moves unsmooth. Vertical hex bar moves unsmooth.	Incorrect position of square plate Incorrect position of hex plate	Refer to chapter 5 How to adjust the locking plate
Tilt arm moves too fast or too slow.	Exhaust air speed of tilt cylinder is too fast or too slow; Low air pressure.	Remove the side panel and adjust the air valve.
Chassis pedal not return.	Pedal return spring damage	Change torsion spring
Motor not rotate or the output torque not enough	Drive system jam Capacitor broken down Voltage not enough Short-circuit	Remove the jam Change capacitor Wait for the restore of the voltage Remove
Cylinder output force not enough	Air leakage Mechanic fault Air pressure not enough	Change sealing parts Remove the fault Adjust the air pressure to meet the requirement